

# Paper Machine Gauge

Stainless Steel Case / Brass Internals / 3.5" Hinged Ring Front Flange



Special Application Gauges



Marsh Instruments Paper Machine Gauges are available in nine ranges and fit existing panel cutouts. The heavy-duty stainless steel case features a front flanged/hinged ring design which allows easy access for pointer adjustment. A restrictor is standard.

## Features:

- 3.5" Diameter to Fit Existing Panels
- Hinged Ring Stainless Steel Case
- Protective Weather Tight Seal

## Product Dimensions

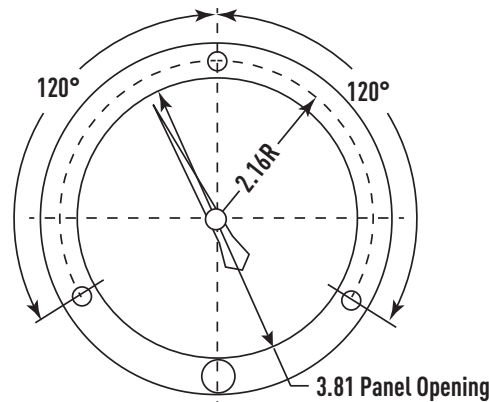
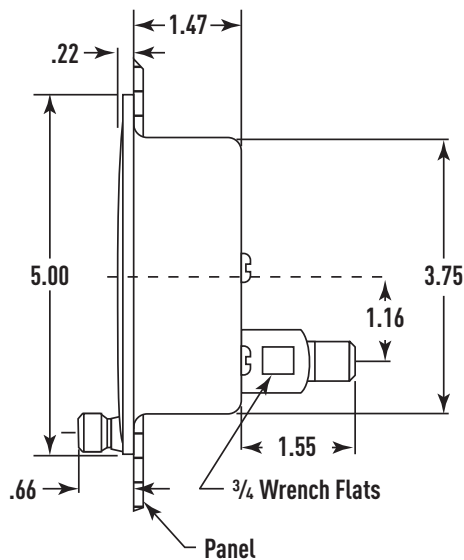

.22 Dia. Hole for #10-32 Screw  
3 Holes

## Product Specifications

### Design

Meets/Exceeds ASME B40.100

### Accuracy

±2 1/2% (ASME Grade A)

### Dial Size(s)

3 1/2" Diameter (76 mm)

### Case

Stainless Steel

### Bezel

Stainless Steel Hinged Ring

### Tube & Socket

Copper Alloy

### Movement

Stainless Steel

### Connection

1/4 NPT - Lower Back Mount Hinged Ring  
Front Flanged Panel Mount

### Pressure Ranges

30 to 1,000 psi

### Standard Scale

Single Scale psi

### Dial Color

Black Markings on White

### Pointer

Aluminum, Black Painted

### Window

Glass

### Standard Case Fill

N/A

### Ambient Temperature

-40° to 160°F

### Vent Plug

N/A

### Weight

1.0 lb.