

LSS Series - Low Pressure

Stainless Steel Case / Stainless Steel Internals



Low Pressure Gauges from Marsh Instruments incorporate a diaphragm element allowing for accurate low-pressure readings in support of a variety of applications, with ASME Grade A 2/1/2% accuracy for ranges above 30" of water. Available ranges include vacuum and pressure in inches of water, ounces per square inch, kilopascals, and millimeters of mercury.

Features:

- Stainless Steel Case & Internals
- Weatherproof-Hermetically Sealed Case

Product Dimensions

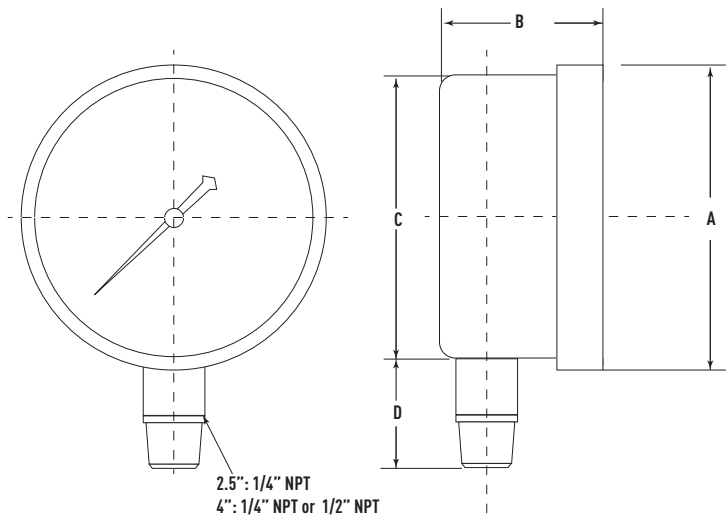

Product Specifications

Design

Meets/Exceeds ASME B40.100

Accuracy

For Ranges 30" H₂O and Above:

±2/1/2% (ASME Grade A)

For Ranges Below 30" H₂O:

±3/1/3%

Dial Size(s)

2.5" Diameter (63 mm)

4" Diameter (100 mm)

Case

304 Stainless Steel

Bezel

304 Stainless Steel - Removable

Tube & Socket

316 Stainless Steel

Movement

Stainless Steel

Connection

2.5" 1/4" NPT - Lower Mount

4" 1/4" or 1/2" NPT - Lower Mount

Pressure Ranges

Low Pressure Vacuum + Pressure

10" H₂O through 10 psi

Standard Scale

Dual Scale with kPa

Triple Scale: oz/in², in H₂O, & kPa

Dial Color

Black Markings on White

Pointer

Aluminum, Black Painted

Window

Glass

Standard Case Fill

Dry, Non-Fillable

Ambient Temperature

-40° to 160°F

Vent Plug

N/A

Weight

2.5" 0.5 lb.

4" 1.0 lb

Dial Size	A	B	C	D
2.5"	2.81"	1.85"	2.56"	0.98"
4"	4.21"	1.93"	3.86"	1.24"

Low Pressure Gauges