

D52/56 Series Test Gauge

Steel Case / Stainless Steel Internals / 4.5" Lower Mount

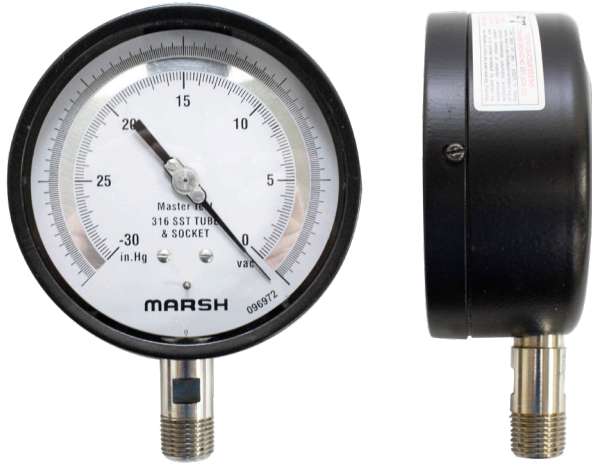

The Marsh Instruments Test Gauge is designed with a black painted steel housing and 316 stainless steel tube and socket to meet the demanding service needs of various test gauge applications. Accuracy is 0.5% of full span. A highly polished integral mirror is positioned between the two graduation arcs on the dial face. The knife-edge pointer is reflective so that, when the pointer and its reflection are in alignment, parallax is virtually eliminated and a true dial reading is assured.

Features:

- 0.5% Full Scale Accuracy
- Adjustable micrometer knife-edge pointer with mirror dial
- Stainless Steel Movement
- Ranges to 10,000 psi

Product Dimensions

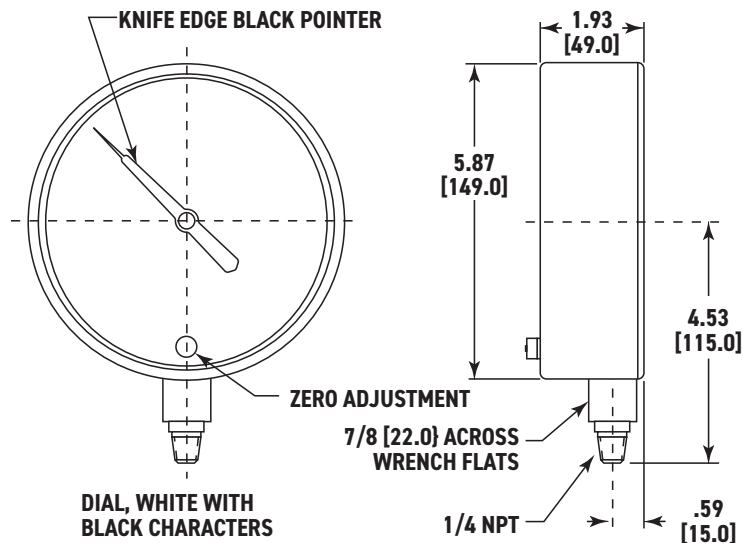

Product Specifications

Design

Meets/Exceeds ASME B40.100

Accuracy

±0.5% Accuracy (ASME Grade 2A)

Dial Size(s)

4 1/2" Diameter

Case

Steel, Black Painted

Bezel

Steel, Black Painted

Tube & Socket

316 Stainless Steel

Movement

Stainless Steel

Connection

1/4 & 1/2 NPT - Lower Mount

Pressure Ranges

VAC/Compound to 10,000 psi

Standard Scale

Dual Scale psi and kPa

Dial Color

Black Markings on White with Mirror Dial to Avoid Parallax

Pointer

Aluminum, Black Painted, Micro-Adjustable, Knife Edge

Window

Instrument Glass

Standard Case Fill

Dry, Non-Fillable

Ambient Temperature

-40° to 160°F

Vent Plug

Blowout Plug

Weight

3.0 lb.